

Note 说明:

- Size of equipment is $\phi 5600 \times 26753$ mm, weight is 1180t, drawings provide by client. 设备规格是 $\phi 5600 \times 26753$ mm, 重量是 1180t. 设备图纸由业主提供.
- All diemnsions are in milimeters (mm) unless otherwise stated. 图中所有尺寸单位均为毫米 (mm), 除非另有说明.
- All details are provisional and are subject to confirmation. 所有细节均为暂定, 需要根据信息随时更新.
- Rubber/plywood will be installed between trailer and beam. 轴线车板和横梁之间应该铺设橡胶垫或枕木.
- Lashing point will be confirmed. 绑扎点待确定.
- Longitudinal road gradient: 3%. 考虑运输道路纵向道路坡度: 3%.
- Transversal road gradient: 2%. 考虑运输道路横向道路坡度: 2%.
- Maximum wind speed during transport: 10.0m/s. 运输过程中允许最大风速: 10m/s.

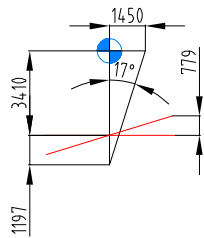

Geometric Trimming Diagram
稳定角

轴挂车规格 Trailer specification

2组PPU+4纵列22轴 2PPU+4FilesX22Axles

所有重量均以公吨为单位 all weights in t	Total	GroupA	GroupB	GroupC	GroupD
轴线条数 Number of axles lines	22.0	11	11	11	11
纵列数 Number of files	4	2	2	2	2
负载详情 Load details					
模块受载 Pay load	1180.0	295.00	295.00	295.00	295.00
车辆自重 Transporter weight	198.0	49.5	49.5	49.5	49.5
动力头重量 Engine weight	16.0	-5.0	13.0	13.0	-5.0
鞍座重量 Saddle weight	50	12	13	13	12
偏载重量 Over load		27	28	27	28
总重量 Total weight	1444.0	378.5	398.5	397.5	379.5
单轴线荷载 Load per axle		34.4	36.2	36.1	34.5
对地压力 t/m ² GBP		10.1	10.6	10.6	10.1
编点压力值 bar GPB		214	225	224	215

01	2025/07/21			
版本 Rev.	时间 Date	编制 Prepared	审核 Checked	批准 Approved
中国石油化工股份有限公司九江分公司				
中国石化 中石化重型起重运输工程有限责任公司 SINOPEC SINOPEC HEAVY LIFTING & TRANSPORTATION CO., LTD.				
加氢裂化装置				
加氢精制反应器 (0203A-R-101) 运输装载图				图幅 Sheet A3
比例 Scale 1:1000				第 01 页 共 1 页 Sheet 1 of 1
工程类别 Engineering category	运输作业 Transportation	施工位置 Construction location	江西省 Jiangxi Province	供施工 For construction
工程编号 Project No.	SLT-TR-SDHM	图纸编号 Drawing No.	SLT-TR-JJSH-PC-03	

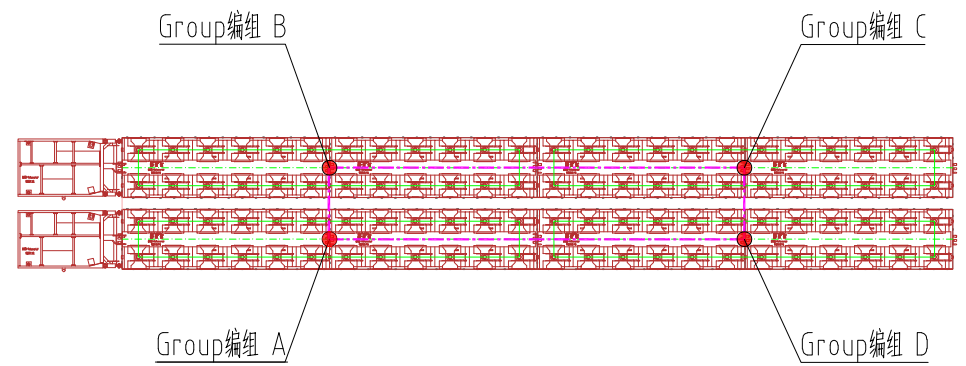
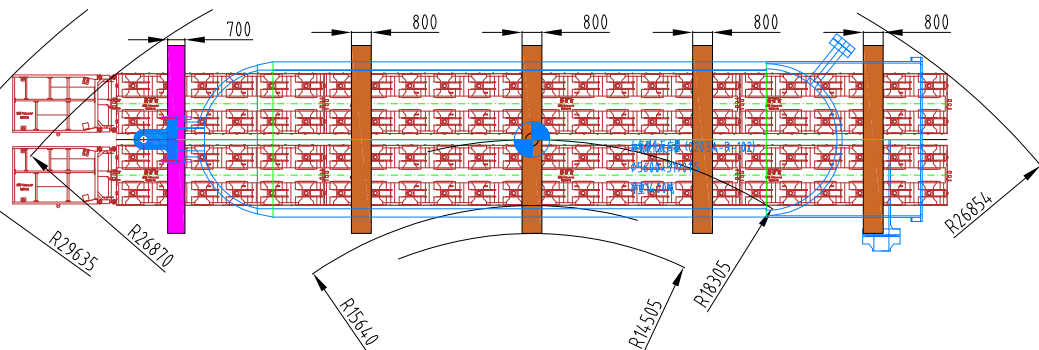
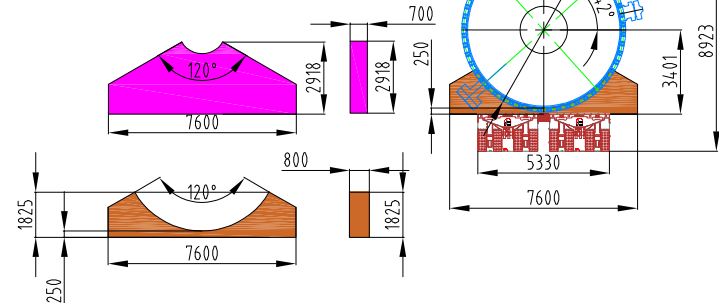
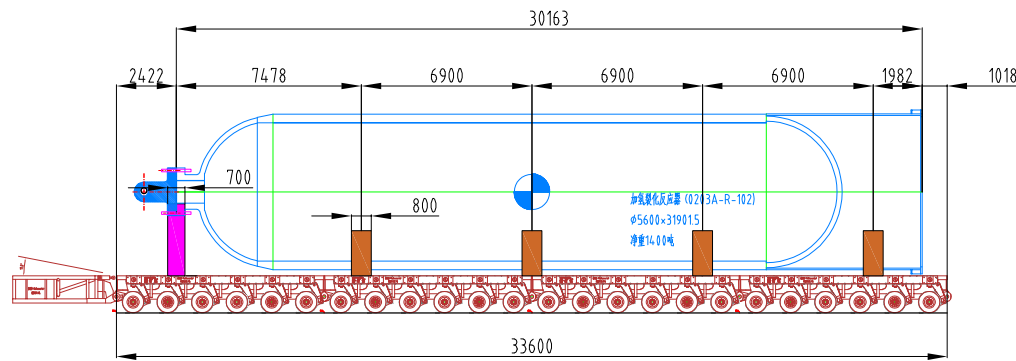

- Note 说明:
- Size of equipment is $\phi 5600 \times 30163$ mm, weight is 1400t, drawings provide by client. 设备规格是 $\phi 5600 \times 30163$ mm, 重量是 1400t. 设备图纸由业主提供.
 - All dimensions are in millimeters (mm) unless otherwise stated. 图中所有尺寸单位均为毫米 (mm), 除非另有说明.
 - All details are provisional and are subject to confirmation. 所有细节均为暂定, 需要根据信息随时更新.
 - Rubber/plywood will be installed between trailer and beam. 轴线和横梁之间应该铺设橡胶垫或枕木.
 - Lashing point will be confirmed. 绑扎点待确定.
 - Longitudinal road gradient: 3%. 考虑运输道路纵向道路坡度: 3%.
 - Transversal road gradient: 2%. 考虑运输道路横向道路坡度: 2%.
 - Maximum wind speed during transport: 10.0m/s. 运输过程中允许最大风速: 10m/s.

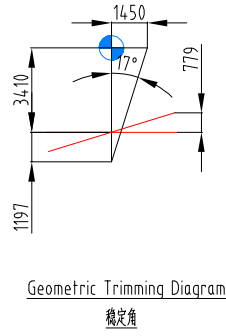

轴车规格 Trailer specification					
2组PPU+4纵列24轴 2PPU+4FilesX24Axes					
所有重量均以公吨为单位 all weights in t	Total	GroupA	GroupB	GroupC	GroupD
轴数 Number of axles lines	24.0	12	12	12	12
纵列数 Number of files	4	2	2	2	2
负载详情 Load details					
模块受载 Pay load	1400.0	350.00	350.00	350.00	350.00
车辆自重 Transporter weight	216.0	54.0	54.0	54.0	54.0
动力头重量 Engine weight	16.0	-5.0	13.0	13.0	-5.0
鞍座重量 Saddle weight	50	12	13	12	13
偏载重量 Over load	126	31	32	31	32
总重量 Total weight	1808.0	442.0	462.0	460.0	444.0
单轴线荷载 Load per axle		36.8	38.5	38.3	37.0
对地压力 t/m ² GBP		10.8	11.3	11.3	10.9
编点压力值 bar GPB		229	239	239	230

01	2025/07/21			
版本 Rev.	时间 Date	编制 Prepared	审核 Checked	批准 Approved
中国石油化工股份有限公司九江分公司				
		中石化重型起重运输工程有限责任公司 SINOPEC HEAVY LIFTING & TRANSPORTATION CO., LTD.		
加氢裂化装置				
加氢裂化反应器 (0203A-R-102) 运输装载图				图幅 Sheet A3
比例 Scale 1:1000				第 01 页 共 1 页 Sheet 1 of 1
工程类别 Engineering category	运输作业 Transportation	施工位置 Construction location	江西省 Jiangxi Province	
工程编号 Project No.	SLT-TR-JJSH	图纸编号 Drawing No.	SLT-TR-JJSH-JQLH-01	
		供施工 For construction		